

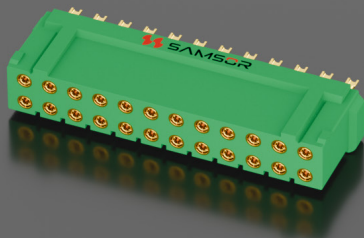

JL23 Series

PCB Connector

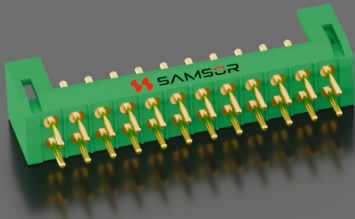
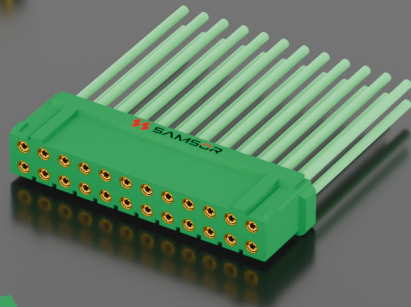
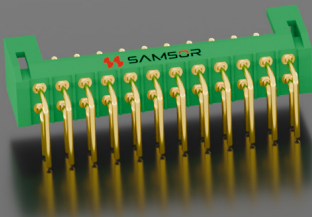
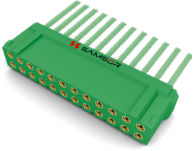

Product Selection Guide

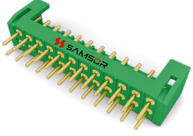
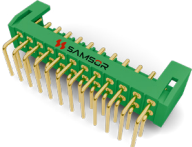
JL23 Standard Series		
 <p>2</p>	 <p>3</p>	 <p>4</p>
Pre-wired Plug	Pre-wired Plug(Double-Ended Cable)	Solder Cup Plug
 <p>5</p>	 <p>6</p>	
Vertical PCB Receptacle	Right Angle PCB Receptacle	

Features

Corresponding to the National Military Standard GJB 1438A-2006
Number of Contacts: Available in 14 configurations with 6, 8, 10, 12, 14, 16, 18, 20, 22, 24, 26, 28, 34 and 40 pins
Hyperboloid spring socket contact structure, with 2.54mm standard grid spacing, arranged in a double row
Conductor cross-sectional area suitable for 0.07mm ² to 0.2mm ² . For thinner wires, modification is required; please specify when ordering. Default supply: 0.12mm ² green high-temperature silver-plated wrapped wire

Performance Specifications

Operating Temperature: -65°C~ +125°C	Dielectric Withstand Voltage: 1000V (AC)
Rated Voltage: 300V AC	Durability: 500 times
Rated Current: 3A	Vibration: 10Hz~2000Hz acceleration 147m/s ² Interruption duration ≤ 1μs
Insulation Resistance: ≥ 5000MΩ (at normal condition)	Shock: 980m/s ² Interruption duration ≤ 1μs

How to order

Series: JL23	JL23 - × ZJ/TK × - S (Note)
Contact Layout: 6、8、10、12、14、16、18、20、22、24、26、28、34、40	
Contact Type: ZJ - Receptacle with Pin TK - Plug with Socket	
Termination Type: B - Straight Board Mount W - Right angle Board Mount Y - Pre-wired H - Solder Cup	
Cable Type: S - Double-ended Cable Omit - Single-ended Cable	

Note: Wire Requirements for Pre-wired Product

If not specified, the default configuration is L=200 mm, AFR250 - 0.12mm²-250V, Green

If there are other requirements, specify as follows: Wire length (from the rear exit point, unit: mm, default: 200mm); Braid shield (P - Lightweight braided shield; default: no braid shield); Nylon sleeve (F - for military green nylon sleeve; Default: No nylon sleeve); Wire Grade (commonly AFR250, default AFR250); Wire Gauge (compatible with 0.07mm² - 0.2mm², default: 0.12mm²); Wire Color (optional multiple colors, default: green), Default items may be omitted; all other requirements can be noted. The above notes do not appear on product markings. They only serve as wire requirements for ordering pre-wired products with leads. For additional wiring definitions or requirements, please contact our engineers.

Note Examples:

(L600PF AFR250 0.15 Green) - Length: 600mm, green wire, type AFR250, Gauge: 0.15mm², braided shielding over wire; nylon sleeve over shielding

(L300F 0.1) - Length: 300mm, green wire, type AFR250, Gauge: 0.1mm², without braid shield, with nylon sleeve over the wire

Pre-wired Plug

JL23	-	24	TK	Y	-	L	(Note)
------	---	----	----	---	---	---	--------

Series: JL23

Contact Layout: 6, 8, 10, 12, 14, 16, 18, 20, 22, 24, 26, 28, 34, 40

Contact Type: TK - Plug with Socket

Termination Type: Y - Pre-wired

Wire Length: Default wire length is L = 200 mm

Note: For wire configuration, please refer to the notes in the "Model Naming" section

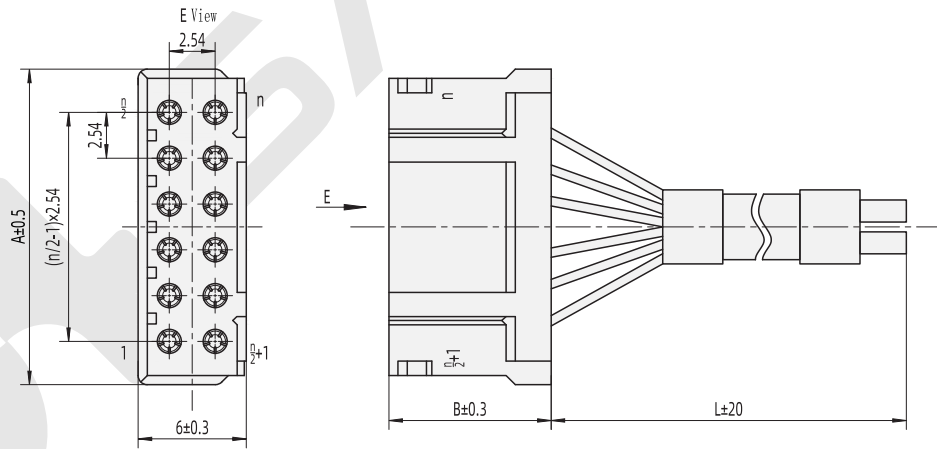
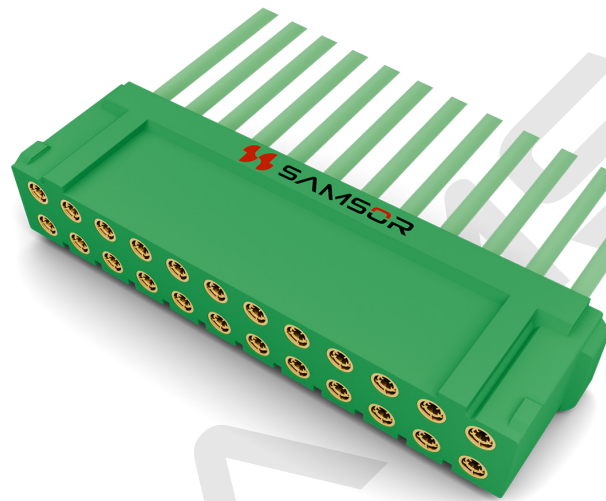

Type	A	B	n(Layout)	Type	A	B	n(Layout)
JL23-6TKY-L	9.9	9	6	JL23-20TKY-L	27.6	9	20
JL23-8TKY-L	12.4	9	8	JL23-22TKY-L	30.1	9	22
JL23-10TKY-L	14.9	9	10	JL23-24TKY-L	32.6	9	24
JL23-12TKY-L	17.5	9	12	JL23-26TKY-L	35.2	9	26
JL23-14TKY-L	20	10	14	JL23-28TKY-L	37.7	9	28
JL23-16TKY-L	22.5	9	16	JL23-34TKY-L	45.4	9	34
JL23-18TKY-L	25	9	18	JL23-40TKY-L	53	9	40

Pre-wired Plug

JL23 - 24 TK Y -S - L (Note)

Series: JL23

Contact Layout: 6、8、10、12、14、16、18、20、22、24、26、28、34、40

Contact Type: TK - Plug with Socket

Termination Type: Y - Pre-wired

Cable Type: S - Double-ended Cable

Wire Length: Default wire length is L = 200 mm

Note: For wire configuration, please refer to the notes in the "Model Naming" section

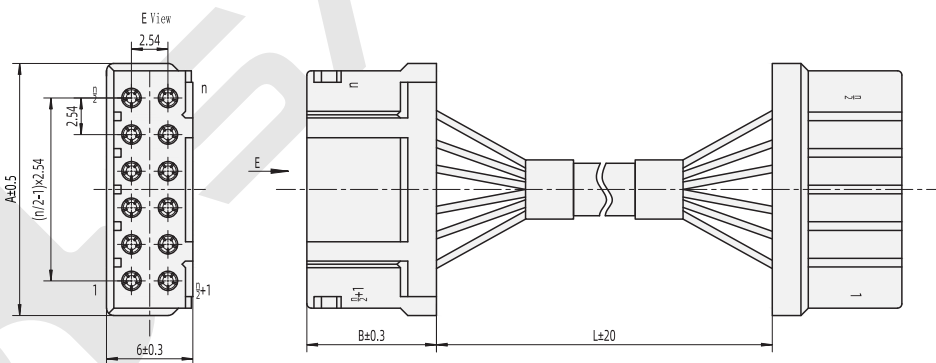
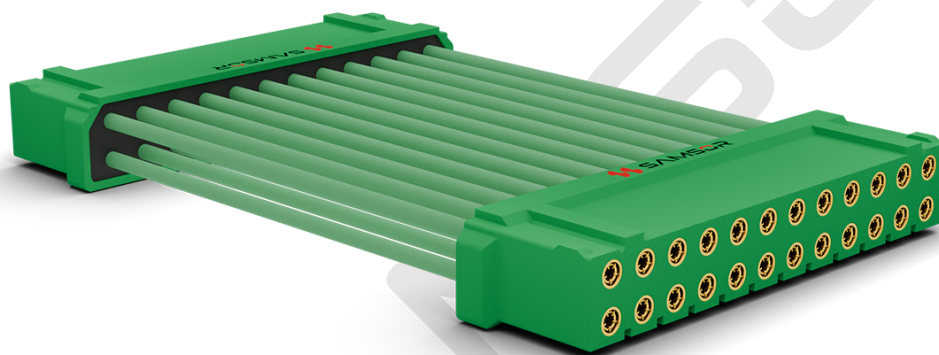

Type	A	B	n(Layout)	Type	A	B	n(Layout)
JL23-6TKY-SL	9.9	9	6	JL23-20TKY-SL	27.6	9	20
JL23-8TKY-SL	12.4	9	8	JL23-22TKY-SL	30.1	9	22
JL23-10TKY-SL	14.9	9	10	JL23-24TKY-SL	32.6	9	24
JL23-12TKY-SL	17.5	9	12	JL23-26TKY-SL	35.2	9	26
JL23-14TKY-SL	20	10	14	JL23-28TKY-SL	37.7	9	28
JL23-16TKY-SL	22.5	9	16	JL23-34TKY-SL	45.4	9	34
JL23-18TKY-SL	25	9	18	JL23-40TKY-SL	53	9	40

Solder Cup Plug

JL23	-	24	TK	H
------	---	----	----	---

Series: JL23

Contact Layout: 6, 8, 10, 12, 14, 16, 18, 20, 22, 24, 26, 28, 34, 40

Contact Type: TK - Plug with Socket

Termination Type: H - Solder Cup

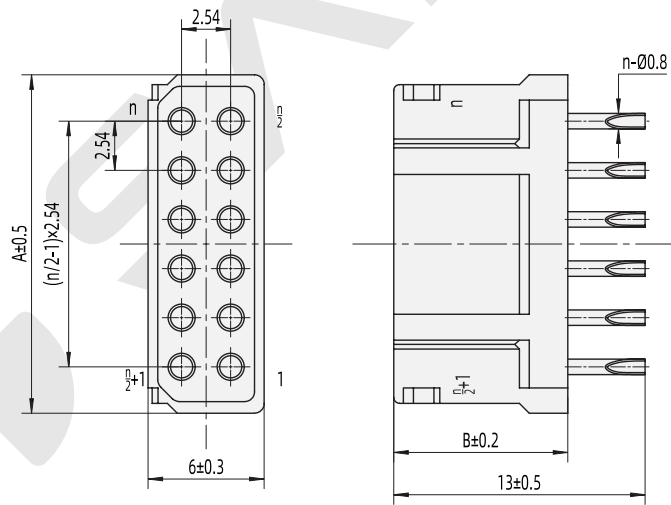
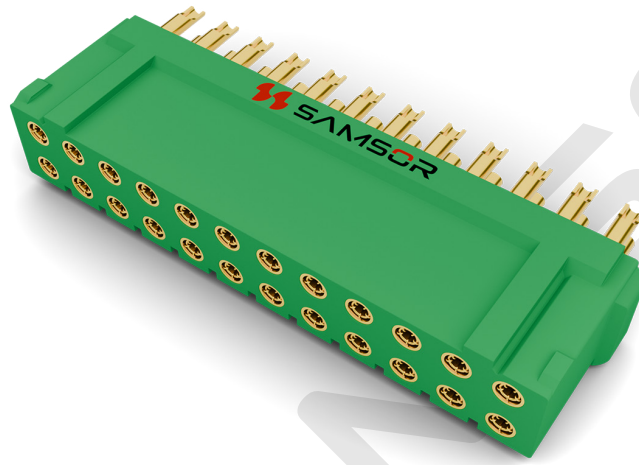

Type	A	B	n(Layout)	Type	A	B	n(Layout)
JL23-6TKH	9.9	9	6	JL23-20TKH	27.6	9	20
JL23-8TKH	12.4	9	8	JL23-22TKH	30.1	9	22
JL23-10TKH	14.9	9	10	JL23-24TKH	32.6	9	24
JL23-12TKH	17.5	9	12	JL23-26TKH	35.2	9	26
JL23-14TKH	20	10	14	JL23-28TKH	37.7	9	28
JL23-16TKH	22.5	9	16	JL23-34TKH	45.4	9	34
JL23-18TKH	25	9	18	JL23-40TKH	53	9	40

PCB Receptacle-Vertical

JL23	-	24	ZJ	B	-	XX
------	---	----	----	---	---	----

Series: JL23

Contact Layout: 6, 8, 10, 12, 14, 16, 18, 20, 22, 24, 26, 28, 34, 40

Contact Type: ZJ - Receptacle with Pin

Termination Type: B - Straight Board Mount

Pin Length: No marking: Default length is 4.0mm -2: Default length is 5.5mm -3: Default length is 7.0mm

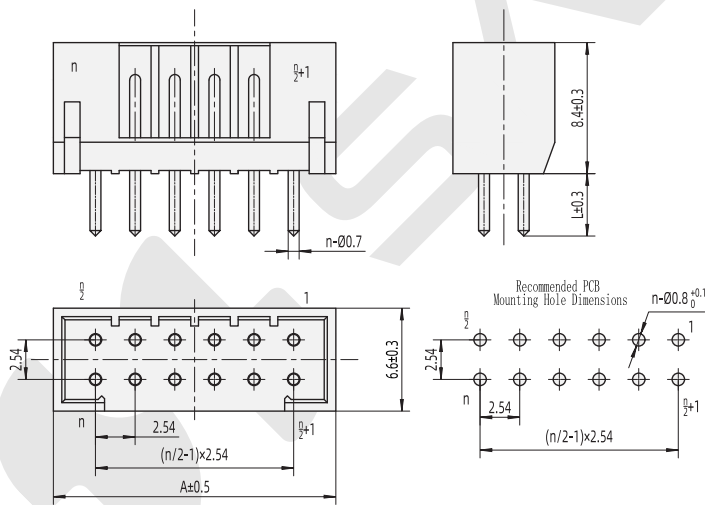
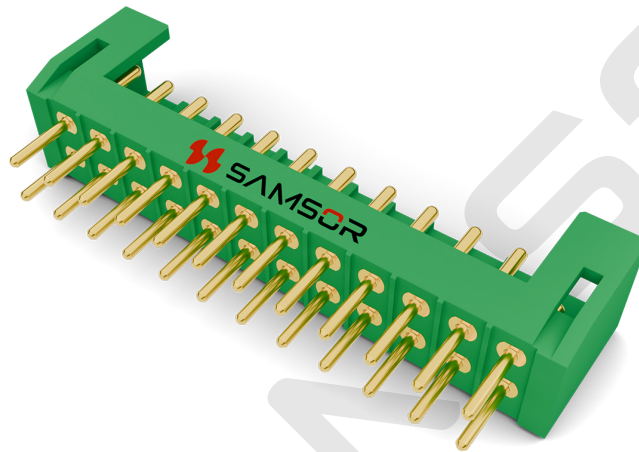

- JL23-ZJB: Standard type, L=4.0mm
- JL23-ZJB-2: Extended pin type, L=5.5mm
- JL23-ZJB-3: Extended pin type, L=7.0mm

Type	A	n(Layout)	Type	A	n(Layout)
JL23-6ZJB	10.5	6	JL23-20ZJB	28.2	20
JL23-8ZJB	13	8	JL23-22ZJB	30.7	22
JL23-10ZJB	15.5	10	JL23-24ZJB	33.2	24
JL23-12ZJB	18.1	12	JL23-26ZJB	35.8	26
JL23-14ZJB	20.6	14	JL23-28ZJB	38.3	28
JL23-16ZJB	23.1	16	JL23-34ZJB	46	34
JL23-18ZJB	25.6	18	JL23-40ZJB	53.6	40

PCB Receptacle-Right Angle

JL23	-	24	ZJ	W
------	---	----	----	---

Series: JL23

Contact Layout: 6, 8, 10, 12, 14, 16, 18, 20, 22, 24, 26, 28, 34, 40

Contact Type: ZJ - Receptacle with Pin

Termination Type: W - Right angle Board Mount

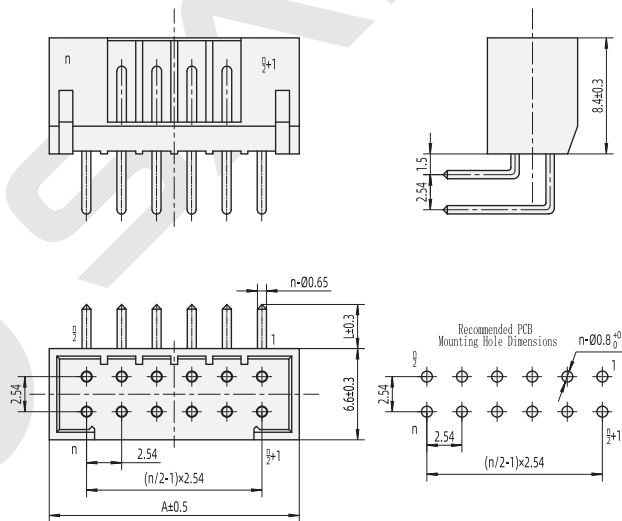
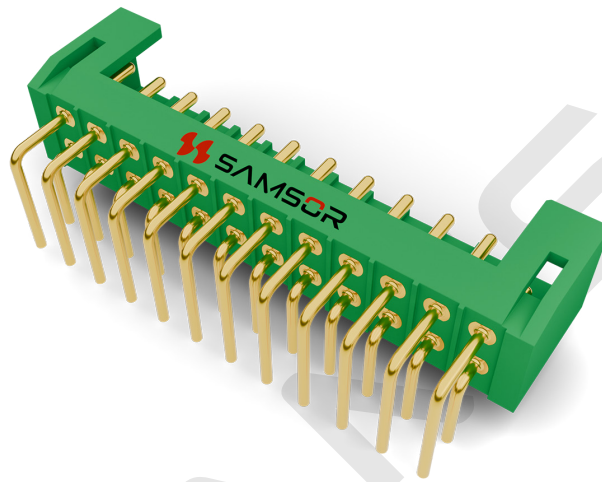

Type	A	n(Layout)	Type	A	n(Layout)
JL23-6ZJW	10.5	6	JL23-20ZJW	28.2	20
JL23-8ZJW	13	8	JL23-22ZJW	30.7	22
JL23-10ZJW	15.5	10	JL23-24ZJW	33.2	24
JL23-12ZJW	18.1	12	JL23-26ZJW	35.8	26
JL23-14ZJW	20.6	14	JL23-28ZJW	38.3	28
JL23-16ZJW	23.1	16	JL23-34ZJW	46	34
JL23-18ZJW	25.6	18	JL23-40ZJW	53.6	40

Note

- The through-hole diameter for the solder pin mounting shall be greater than 0.8 mm (or 31 mil as specified), otherwise the solder pin may not pass through the PCB
- The solder pin length (L) shall be selected according to the PCB thickness (H). To ensure soldering quality, it is recommended that $L - H \geq 1$ mm
- During soldering, the insulator must be flush with the PCB surface. Tilting or suspending the insulator is strictly prohibited
- For manual soldering, a solder temperature of $(260 \pm 10)^\circ\text{C}$ is recommended, with soldering time not exceeding 5 seconds. When using a constant-temperature soldering iron at $(350 \pm 10)^\circ\text{C}$, the soldering time should be (2~3) seconds